

Intend **GRACE**

FR/EN/Trail/XC/CC

- Manual -

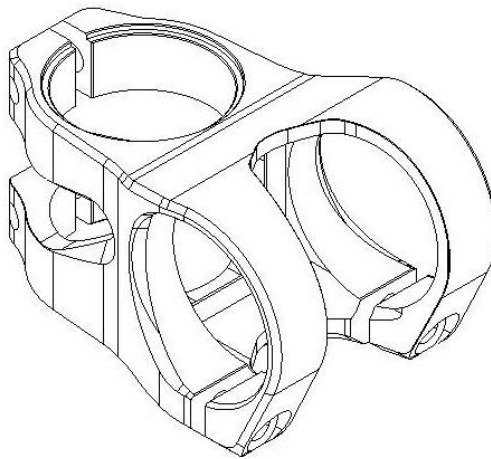

Construction:

The Intend GRACE EN/Trail/XC is a one piece stem with the purpose to combine steerer tube and handlebar safe and strong.

Due to his special technique the Intend Grace has only 4 instead of the usual 6 bolts. This is why the weight of the stem is very low without a limitation of the fatigue and strength.

Technical Data:

- **35mm/50mm/77mm** length
- **28,6mm** steerertubediameter
- **31,8mm/35mm** handlebar diameter
- 4x **M5x16mm** bolts at EN/Trail, 4x **M4x15mm** at XC
- **4mm** allen wrench size at EN/Trail, 3mm at XC

Torque Grace FR/EN/Trail:

The maximal torque of the handlebar bolts is **5 Nm**.

The maximal torque of the steerer bolts is **5 Nm**.

Torque Grace XC/CC:

The maximal torque of the handlebar bolts is **4 Nm**.

The maximal torque of the steerer bolts is **4 Nm**.

The bolts should be greased a little bit. This is already done at delivery. It avoids a cold-welding of the bolts and the aluminum.

The kind of grease does not matter.

Assembly:

Due to the special 4 bolt technique, the correct assembly is important. The contact clamping areas should be clean and with no dirt.

Please remove the handlebar clamp bolts. There is a 30° chamfer in the handlebar bore to make an easier assembly.

It is important that the handlebar rise looks **BACK** in the direction of the stem, because in this direction the stem has his lowest width. This is shown in the next picture. This pics are made with the Grace EN but is identical to all other Intend stems.



To get the handlebar in the stem the handlebar clamp has to be opened slightly with the included wooden spoon. The easiest way is shown in the pic, look at the chamfer ! (Fase am Holz)! Please note that the wooden spoon should not extend in the handlebardiameter because the handlebar should take place there later.

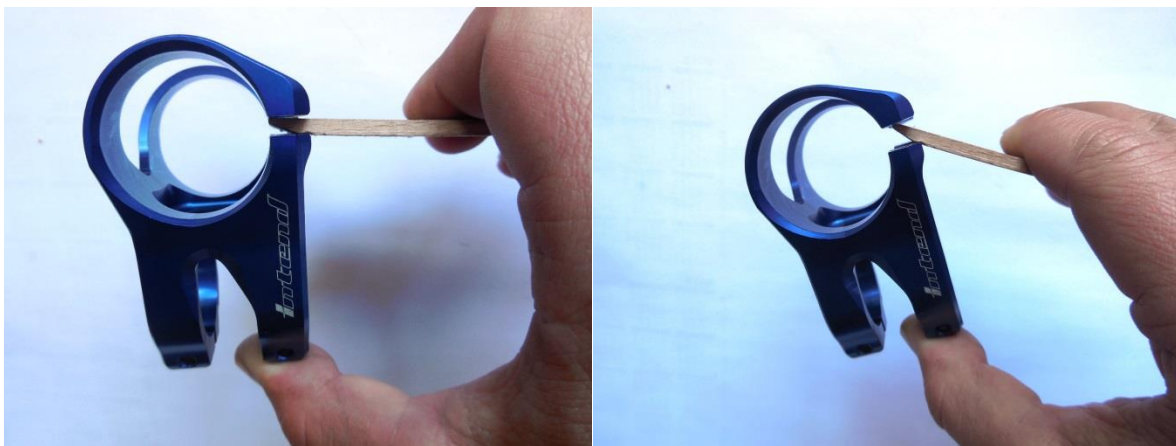

Now you have to push in the handlebar, the easiest way to get this handled is shown with this position of your hand.



Please Note: if this step is done not carefully, the surface can get some slight scratches. The stem has to be opened wide enough to ensure not to need to much force pushing in the handlebar.

Depending on the design of the handlebar, it can be that it is a little bit difficult to avoid scratches for 100%

If someone is very critical with scratches, it can be useful to use some TESA stripes on the handlebar. I can't give a guarantee that there will be no scratches on your handlebar. If you are not sure – please take another stem! ☹

Tip: For not-clamped grips you can push it over the grip normally.



After assembly of the stem and fastening of the bolts please check if the stem is really fixed on the steerer by clamp the front wheel between your legs and try to turn the handlebar.

Riding purpose:

The Intend Grace FR, EN and Trail is ready for downhill riding.

The Intend Grace XC and CC is ready for cross country and allmountain riding.